

KASON Reach-in Hardware

	Hinges Adjustable, spring, cam-rise, flange & pivot	48-53
	Latches Magnetic, edgemount, mechanical & trigger action	54-58
	Compensation Valves Internal, external	59
	Evaporator Trays Designed for longer life and energy savings	59

FULL KASON
CATALOGUE
AVAILABLE
ON REQUEST

Kason Hinge Selector

This Hinge Selector is to assist you in choosing the correct Kason hinges for commercial refrigeration, foodservice equipment, transportation, industrial and many other uses.

The Load Chart, below, shows our recommended allowable load per pair of hinges for each hinge group.

The data applies for normal conditions under static loading by door weight only. Other factors, such as positive or negative pressure, very high gasket compression, vibration, corrosive or abrasive atmospheres, or structural movement are not taken into account. It is the final responsibility of the users to determine the suitability and capacity required in their specific applications.

Load Chart

Door Weights																						
kg	lb																					
226.8	500	D	D	E	F	F	F	G	G	G	G	H	H	H	H	H	H					
217.7	480	D	D	E	F	F	F	G	G	G	G	H	H	H	H	H	H					
208.6	460	D	D	E	E	F	F	F	G	G	G	G	H	H	H	H	H	H				
199.5	440	D	D	D	E	F	F	F	G	G	G	G	G	H	H	H	H	H	H			
190.5	420	D	D	D	E	F	F	F	F	G	G	G	G	H	H	H	H	H	H	H		
181.4	400	D	D	D	E	E	F	F	F	G	G	G	G	G	H	H	H	H	H	H	H	
172.4	380	D	D	D	D	E	F	F	F	F	G	G	G	G	G	H	H	H	H	H	H	
163.3	360	D	D	D	D	E	E	F	F	F	G	G	G	G	G	G	H	H	H	H	H	
154.2	340	D	D	D	D	E	E	F	F	F	F	G	G	G	G	G	G	H	H	H	H	
145.2	320	C	D	D	D	D	E	E	F	F	F	F	G	G	G	G	G	G	H	H	H	
136.1	300	C	D	D	D	D	E	E	E	F	F	F	F	G	G	G	G	G	G	H	H	
127.0	280	C	D	D	D	D	D	E	E	F	F	F	F	F	G	G	G	G	G	G	H	
117.9	260	C	C	D	D	D	D	D	E	E	F	F	F	F	F	G	G	G	G	G	G	
108.9	240	C	C	D	D	D	D	D	D	E	E	F	F	F	F	F	F	G	G	G	G	
99.8	220	C	C	C	D	D	D	D	D	D	E	E	E	F	F	F	F	F	F	G	G	
90.7	200	B	C	C	D	D	D	D	D	D	D	E	E	E	F	F	F	F	F	F	G	
81.7	180	B	C	C	D	D	D	D	D	D	D	D	E	E	E	F	F	F	F	F	F	
72.6	160	B	B	C	C	C	D	D	D	D	D	D	D	E	E	E	E	F	F	F	F	
63.5	140	B	B	C	C	C	C	D	D	D	D	D	D	D	D	D	E	E	E	E	F	
54.4	120	B	B	B	C	C	C	C	C	D	D	D	D	D	D	D	D	D	D	E	E	
45.4	100	A	B	B	B	B	C	C	C	C	C	D	D	D	D	D	D	D	D	D	D	
36.3	80	A	A	B	B	B	B	B	C	C	C	C	C	C	D	D	D	D	D	D	D	
27.2	60	A	A	A	A	B	B	B	B	B	B	C	C	C	C	C	C	C	C	C	D	
18.1	40	A	A	A	A	A	A	A	A	B	B	B	B	B	B	B	B	B	C	C	C	
9.0	20	A	A	A	A	A	A	A	A	A	A	A	A	A	A	A	A	A	A	A	B	
Door	Inches	12	15	18	21	24	27	30	33	36	39	42	45	48	51	54	57	60	63	66	69	72
Width	cm	30.5	38.1	45.7	53.3	61.0	68.6	76.2	83.8	91.4	99.1	106.7	114.3	121.9	129.5	137.2	144.8	152.4	160.0	167.6	175.3	182.9

How to Use This Chart

1. Locate the weight of your door in the far left column, headed Door Weight.
2. Find the width of your door along the bottom of the chart.
3. Where the Weight line and Width column intersect, find the recommended hinge group code (A, B, etc.).
4. Select your hinges from the Kason Hinge Groups, below.

NOTE: If exact dimensions and weight for your door is not shown, use the next higher width and weight.

Hinge Groups A – C shown in Kason Reach-in Hardware

Hinge Groups D – H shown in Kason Walk-in Hardware

KASON REACH-IN HARDWARE

Kason Hinge Groups (Order in Pairs)

Group	Hinge Model Numbers (See Reach-in Section)
A	139, 212, 214, 1070, 1216, 1216-13
B	220, 1070A, 1071, 1220
C	1061, 1071A, 1267

Group	Hinge Model Numbers (See Walk-in Section)
D	1241, 1245, 1246, 1251, 1341
E	1074
F	1214, 1409
G	1277, 1277L, 1277S, 1277T, 1377S
H	1075, 1076, 1275, 1276

212 :: Adjustable Hinge



- Positive adjustment compensates for gasket wear
- Interchangeable for right or left opening door

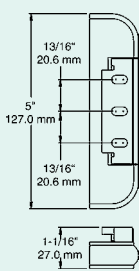

- **Material:** High pressure, die-cast zinc flange; brass cover, zinc plated steel strap
- **Finish:** Highly polished chrome.
- **Adjustment Range:** 4.8mm (3/16")
- **Mounting:** Drilled and countersunk for 5.0mm (No. 10) screws
- **Load Rating:** See Hinge Selector Chart, Group A

- 021200004** Adjustable Hinge, Offset 22.2mm (7/8")
- 021200008** Adjustable Hinge, Offset 28.6mm (1 1/8")
- 021200012** Adjustable Hinge, Offset 34.9mm (1 3/8")

214 :: Adjustable Hinge



- Mounts close to refrigerator door
- Requires minimum jamb width
- Adjustment range is 3.2mm (1/8")
- Easy, positive adjustment by loosening mounting screw and resetting serrated adjustment plate
- Interchangeable for right or left opening door

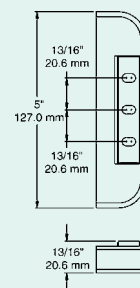

- **Material:** High pressure, die-cast zinc flange and adjustment plate, brass cover, zinc plated steel strap
- **Finish:** Polished chrome
- **Adjustment Range:** 3.2mm (1/8")
- **Mounting:** Drilled and countersunk for 5.0mm (No. 10) screws
- **Load Rating:** See Hinge Selector Chart, Group A.

- 021400004** Adjustable Hinge, Offset 22.2mm (7/8")
- 021400008** Adjustable Hinge, Offset 28.6mm (1 1/8")
- 021400012** Adjustable Hinge, Offset 34.9mm (1 3/8")

220 :: Spring Hinge



- Heavy-duty, long wearing design.
- Fully round pivot pin assures trouble-free operation and long life
- Spring tension adjusts quickly on site
- Adjustable to compensate for gasket compression
- Interchangeable for right or left opening door

- **Material:** High pressure, die-cast zinc flange and adjustment plate, chrome-plated brass cover, zinc plated steel strap.
- **Finish:** Polished chrome.
- **Adjustment Range:** 4.8mm (3/16").
- **Mounting:** Drilled and countersunk for 5.0mm (No. 10) screws.
- **Load Rating:** See Hinge Selector Chart, Group B

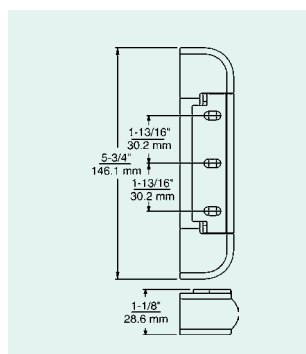

220 Spring Cartridge Kit Installation



1. Assemble spring cartridge as shown.



2. Place thrust washer and bushing over hexagon pin on mounted hinge. Insert adjustment pin into adjustment bushing assembly. Grasping adjustment pin, compress spring and place adjustment bushing assembly over round pin.



3. Adjust tension; then insert stop pin in hole of adjustment bushing assembly.

- 022000008** Spring Hinge, Offset 28.6mm (1 1/8")
- 022000012** Spring Hinge, Offset 34.9mm (1 3/8")
- 022000027** Spring Cartridge Kit

1216 :: Non-Rise Adjustable Hinge



- Great for use on underbar equipment and refrigerators
- Offsets adjust easily by loosening mounting screws and resetting serrated adjustment plate

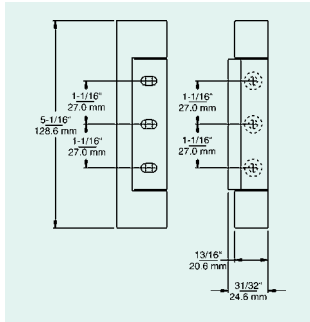

- **Material:** High pressure, die-cast zinc flange and adjustment plate, steel strap, stainless steel cover
- **Finish:** Polished chrome
- **Adjustment Range:** 4.8mm (3/16")
- **Mounting:** Drilled and countersunk for 5.5mm (No. 12) screws
- **Load Rating:** See Hinge Selector Chart, Group A

1220 :: Adjustable Hinge



- Larger non-rise hinge for use on heavier reach-in doors
- Offsets adjust easily; just loosen mounting screws and reset serrated adjustment plate
- Round bearing pins for longer life than competitive models
- Use for right or left opening door
- Simple conversion to spring hinge for self-closing applications

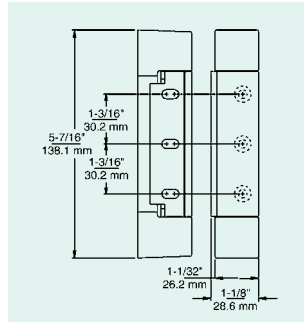

- **Material:** High pressure, die-cast zinc flange and adjustment plate, stainless steel cover, zinc plated steel strap.
- **Finish:** Polished chrome.
- **Adjustment Range:** 4.8mm (3/16").
- **Mounting:** Drilled and countersunk for 5.0mm (No. 10) screws.
- **Load Rating:** See Hinge Selector Chart, Group B.

121600001 Non-Rise Adjustable Hinge, Offset 28.6mm (1 1/8")

121600027 Spring Cartridge Kit

122000008 Adjustable Hinge, Offset 28.6mm (1 1/8")

122000012 Adjustable Hinge, Offset 34.9mm (1 3/8")

022000027 Spring Cartridge Kit

Spring Cartridge Kit Installation

The 1216 and 1220 hinges easily convert to a spring hinge for self-closing applications.



1. Assemble spring cartridge as shown.



2. Slip bushing over hexagon pin on mounted hinge; then insert adjustment pin into adjustment bushing assembly.



3. Grasping adjustment pin, compress spring and place adjustment bushing assembly over round pin.



4. Adjust tension; then insert stop pin in hole of adjustment bushing assembly.

1216-31 :: Hi-Temp Brass Oven Hinge



- Non-rise hinge for right or left hand use
- Designed for ovens, steam cabinets and other heated appliances
- Offsets adjust easily; loosen mounting screws and reset serrated adjustment plate
- Easily convert the 1216-31 Hi-Temp to a Spring Hinge with the 1216-27 Spring Cartridge Kit

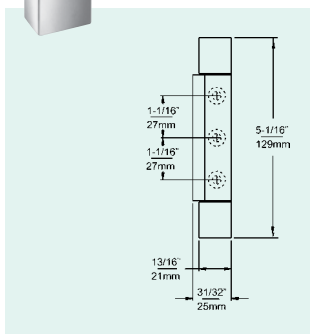

- **Material:** Solid forged brass, Teflon bushing
- **Finish:** Polished chrome
- **Mounting:** Drilled and countersunk for 5.0mm (No. 10) screws
- **Offset:** 28.6mm (1 1/8")
- **Adjustment Range:** 4.8mm (3/16")
- **Load Rating:** See Hinge Selector Chart, Group A

Spring Cartridge Kit Installation

Easily convert the 1216 Hi-Temp Hinge to a spring hinge with this kit.



121600031 Hi-Temp Hinge, Solid Brass

121600027 Spring Cartridge Kit

1267 :: Cam-Rise Hinge



- Beautifully designed and proportioned basic hinge is engineered for heavy use and long life
- Self-lubricating Zytel cam allows door to close automatically or to stay open at 120° angle
- Reversible cam for use on right or left opening door
- Lift-off feature allows door to be removed with hinges in place
- Adjustable to compensate for gasket compression
- Spring assisted version available

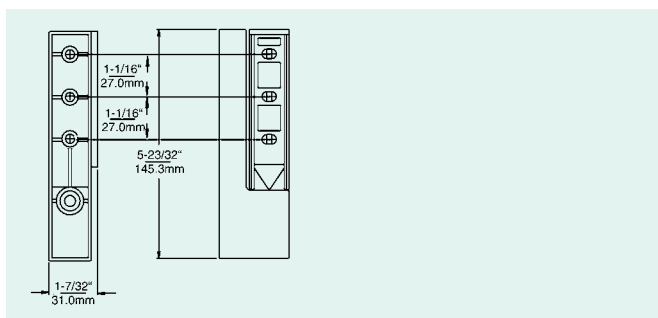

- **Material:** High pressure, die-cast zinc flange, strap and adjustment plate; brass cover
- **Finish:** Polished chrome
- **Offset:** 4.8mm (3/16")
- **Adjustment Range:** 41.3 to 60.3mm (1 5/8" to 2 3/8")
- **Mounting:** Flange and strap drilled and countersunk for 5.5mm (No. 12) flat head screws
- **Load Rating:** See Hinge Selector Chart, Group C

126700014 Cam-Rise Hinge

1467R :: Double Adjustable Cam-Rise Hinge



- Sag-compensating hinge assures correct door alignment the first time, all the time
- Easy flange adjustment positively locks into place after aligning door, so hinge holds firmly in place
- Eliminates floating tapping plates; shims and twisted hinges
- Traditional strap adjustment compensates for gasket compression
- Interchanges in whole or in part with other suppliers' edgmount, cam-rise hinges
- Reversible for right or left hand door mounting

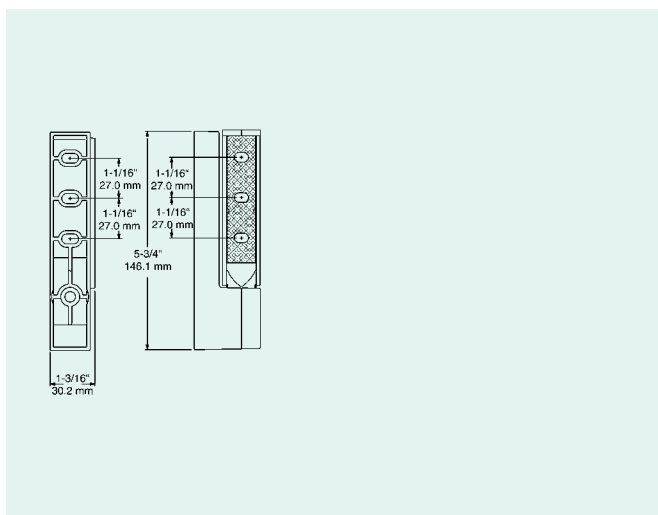

- **Material:** High Pressure die-cast zinc flange, strap, and adjustment plates; stainless steel cover; nylon cam
- **Finish:** Polished chrome
- **Offset Range:** 41.3mm to 60.3mm (1 5/8" to 2 3/8")
- **Mounting:** Drilled and countersunk for 5.5mm (No. 12) flat head screws
- **Other:** Adjustment range for both the flange and strap is 4.8mm (3/16"); 120° cam detent
- **Load Rating:** See Kason Hinge Selector Chart, Group C

1467R00014 Complete Hinge

1467R00001 Recessed Underside Adjustable Flange

1467R00002 Strap

1467R00003 Adjustable Plate

1467R00004 Cover

1467R00005 Cam

1467R00006 Flange Plug

139 :: Narrow Flange Hinge



- Classic styling for small service doors
- Rugged design withstands hard use

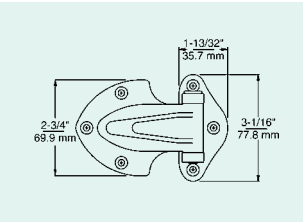

- **Material:** High pressure, die-cast zinc; stainless steel pin
- **Finish:** Polished chrome
- **Offsets:** See ordering information
- **Mounting:** Drilled and countersunk for 4.0mm (No. 8) screws
- **Load Rating:** See Hinge Selector Chart, Group A

- 0139000004** Narrow Flange Hinge, Flush
- 0139000032** Narrow Flange Hinge, Offset 22.2mm (7/8")
- 0139000040** Narrow Flange Hinge, Offset 28.6mm (1 1/8")

1061 :: Steel Hinge



- Equipped with nylon thrust washers

1061BB Ball Bearing Hinge

- Features all metal ball bearing washers for high temperature applications
- Other specifications are the same as the 1061

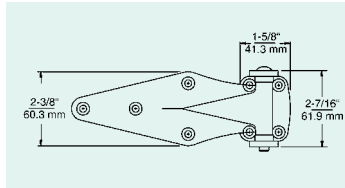

- **Material:** Steel
- **Finish:** Kasonized
- **Mounting:** Drilled and countersunk for 5.0mm (No. 10) screws
- **Load Rating:** See Hinge Selector Chart, Group C

- 1061000004** Steel Hinge, 0.0mm (Flush)
- 1061000036** Steel Hinge, Offset 28.6mm (1 1/8")
- 1061BB0004** Ball Bearing Hinge, 0.0mm (Flush)
- 1061BB0036** Ball Bearing Hinge, Offset 28.6mm (1 1/8")

Narrow Flange Hinges



1070

- Workhorse hinges in two sizes
- High strength with stainless steel through pin

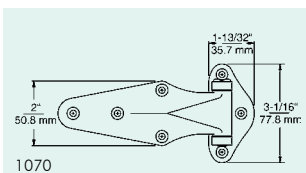

1070

- **Material:** High pressure, die-cast zinc; stainless steel pin
- **Finish:** Polished chrome

1070

- **Mounting:** Drilled and countersunk for 4.0mm (No. 8) screws
- **Load Rating:** See Hinge Selector Chart, Group A

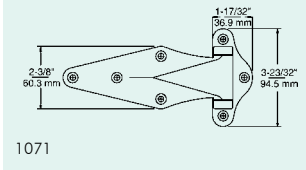

1071

1071

- **Mounting:** Drilled and countersunk for 5.0mm (No. 10) screws
- **Load Rating:** See Hinge Selector Chart, Group B

- 1070000004** Narrow Flange Hinge, Flush
- 1070000032** Narrow Flange Hinge, Offset 22.2mm (7/8")
- 1070000040** Narrow Flange Hinge, Offset 28.6mm (1 1/8")
- 1071000032** Narrow Flange Hinge, Offset 22.2mm (7/8")
- 1071000040** Narrow Flange Hinge, Offset 28.6mm (1 1/8")

Nylon Bearing Hinges



1070A

- Nylon bearing washers provide smooth door swing and long life
- High strength with stainless steel through pin

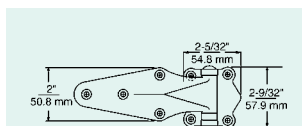

1070A

- **Material:** High pressure, die-cast zinc; stainless steel pin
- **Finish:** Polished chrome

1070A

- **Mounting:** Drilled and countersunk for 4.0mm (No. 8) screws
- **Load Rating:** See Hinge Selector Chart, Group B

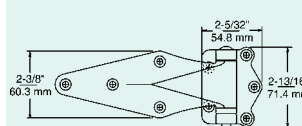

1071A

1071A

- **Mounting:** Drilled and countersunk for 5.0mm (No. 10) screws
- **Load Rating:** See Hinge Selector Chart, Group C

- 1070A00016** Narrow Flange Hinge, Offset 22.2mm (7/8")
- 1070A00024** Narrow Flange Hinge, Offset 28.6mm (1 1/8")
- 1071A00036** Narrow Flange Hinge, Offset 22.2mm (7/8")
- 1071A00044** Narrow Flange Hinge, Offset 28.6mm (1 1/8")

1535 :: Pivot Hinge

- Field-adjustable die-cast zinc spring cartridge lets user select correct tension for smoother door operation
- Cam dwell keeps door open beyond 90° for easy access. Positive stop at 115° prevents interference with adjoining equipment
- Built-in overclose assures constant door pressure and full gasket seal

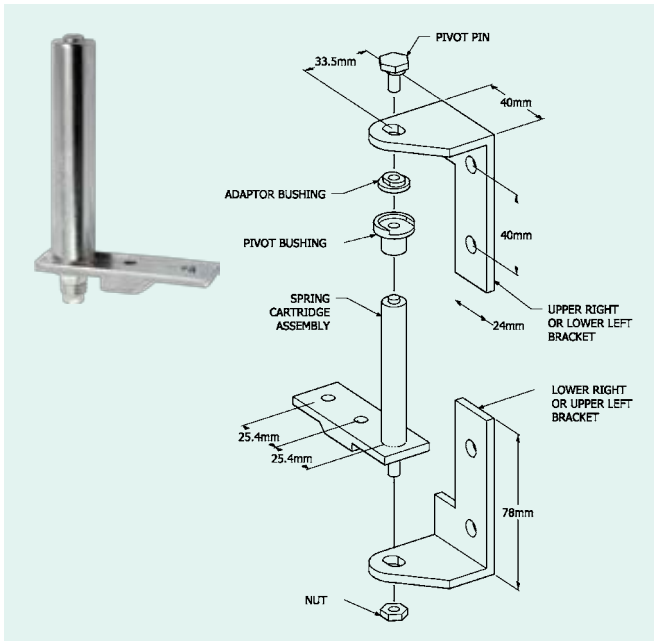

1535-01 Spring Cartridge Assembly with Nut

1535-11 Half-door Plate is also available for use on 'Stable Doors'

1537 Pivot Hinge

- Field-adjustable die-cast zinc spring cartridge lets user select correct tension for smoother door operation
- Cam dwell keeps door open beyond 90° for easy access
- Built-in overclose assures constant door pressure and full gasket seal
- The shorter bracket 1538 may also be used with cartridge assembly 1537

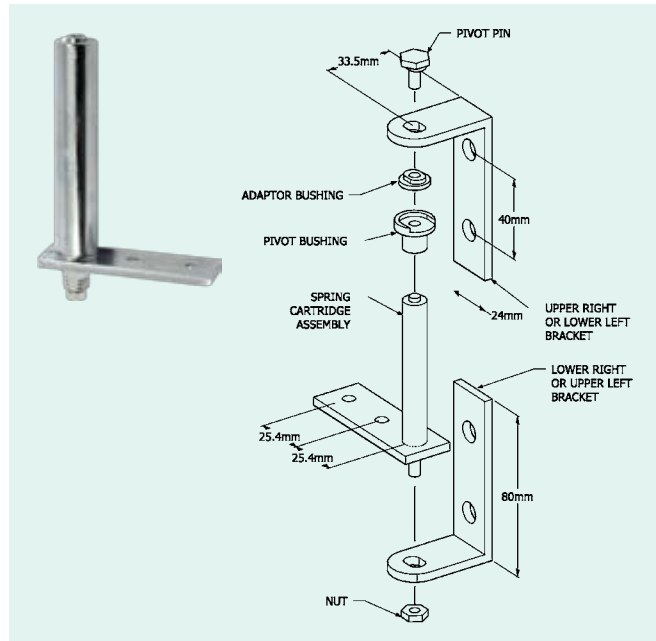

1537-01 Spring Cartridge Assembly with Nut

1537-02 Top Right Hand and Bottom Left Hand Bracket

1537-03 Top Left Hand and Bottom Right Hand Bracket

1539 Pivot Hinge

- Field-adjustable die-cast zinc spring cartridge lets user select correct tension for smoother door operation
- Cam dwell keeps door open beyond 90° for easy access
- Positive stop at 115° prevents interference with adjoining equipment
- Built-in overclose assures constant door pressure and full gasket seal

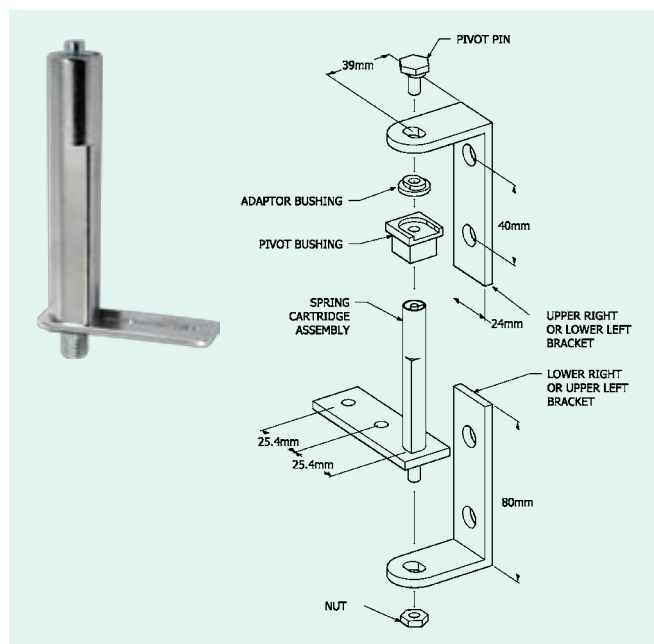

1539-21 Lower Left Spring Cartridge Assembly with Nut

1539-23 Lower Right Spring Cartridge Assembly with Nut

1539-000034 Top Right Hand and Bottom Left Hand Bracket

1539-000035 Top Left Hand and Bottom Right Hand Bracket

170 Series :: Magnetic Latches



- Satisfies NSF standards for all applications
- Four handle styles
- High strength magnetic force keeps door closed and accommodates variations in cabinet construction
- Kason 'breaker action' quickly releases magnet for fast door opening
- Adjustable latch body compensates for gasket wear
- Not affected by door sag

- **Material:** High pressure die-cast zinc body and adjustment plate; zinc die-cast or glass reinforced composite handle; steel strike with nylon spacer
- **Finish:** Polished chrome latch body; black composite or polished chrome handle
- **Handle Styles:** Straight, offset
- **Mounting:** Latch is edge mounted; strike is surface mounted. Drilled and countersunk for 5.0mm (No. 10) screws
- **Standard Magnet:** Nitrile material; holding force approx. 35.0kg (77lb)
- **Optional Ceramic Magnet:** Holding force of 59.0kg (130 lb); recommended for temperature applications above 138.8°C (280°F) or where greater holding power is required

017000008 Offset Composite Handle, Finish: Black, Magnet: Standard

017000018 Offset Composite Handle, Finish: Black, Magnet: Ceramic

017050004 Straight Die-Cast Handle, Finish: Polished Chrome, Magnet: Standard

017050014 Straight Die-Cast Handle, Finish: Polished Chrome, Magnet: Ceramic

017050008 Straight Composite Handle, Finish: Black, Magnet: Standard

017050018 Straight Composite Handle, Finish: Black, Magnet: Ceramic

0170B0024 Offset Die-Cast Handle, Finish: Polished Chrome, Magnet: Standard

0170B0034 Offset Die-Cast Handle, Finish: Polished Chrome, Magnet: Ceramic

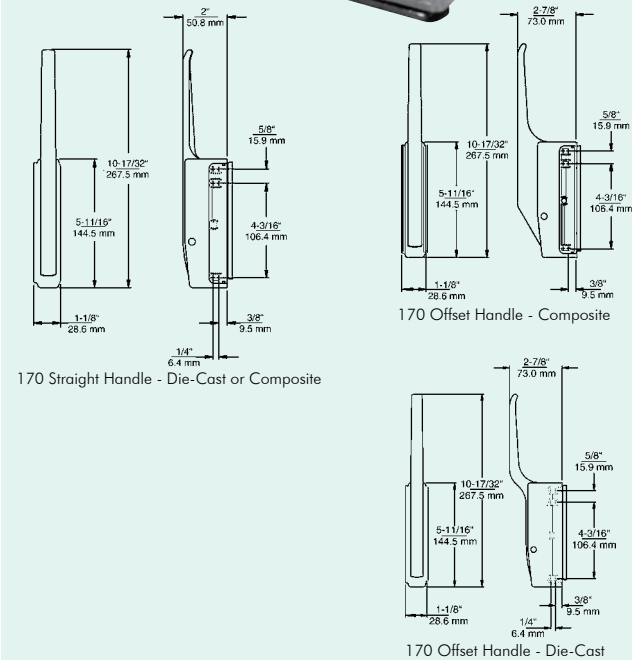

544 :: Compact Magnetic Edgemount Latch



- Compact size for smaller heated cabinets where space is limited
- Non-heat conducting composite, offset handle
- Kason's time-tested magnetic latching system
- Breaker action releases magnet for easy opening
- Operates smoothly with handle mounted up or down
- Not affected by door sag
- Use on right or left opening doors

054400004 Compact Edgemount Latch, Magnet: Standard

054400014 Compact Edgemount Latch, Magnet: Ceramic

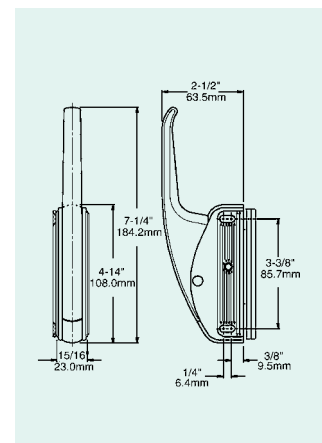

- **Material:** High pressure die-cast zinc body; glass reinforced composite handle; steel strike
- **Finish:** Polished chrome latch body, chrome strike; black composite handle
- **Standard Magnet:** Chemical-resistant Nitrile - holding force approx. 18.1kg (40 lb)
- **Optional Hi-temp Magnet:** Ceramic - holding force of 29.5kg (65 lb). Recommended for temperature applications above 138.8°C (280°F) or where greater holding power is required
- **Mounting:** Latch is edge mounted; strike is surface mounted. Drilled and countersunk for 5.0mm (No. 10) flat head screws

172 :: Magnetic-Mechanical Latch



- Magnetic force combined with mechanical latching provide the ultimate in positive door closure and sealing
- Latch releases with a light touch
- Mechanical latching with cylinder lock offers positive security
- Keeps door shut even when adjacent doors are slammed
- Two-way strike adjustment compensates for door sag and gasket wear
- Unique design of strike ensures full magnetic attraction at each adjustment

- **Material:** High pressure die-cast zinc body, handle and strike
- **Finish:** Polished chrome
- **Handle Styles:** Straight, offset
- **Lock Selection:** Cylinder or non-cylinder locking
- **Mounting:** Latch is edge mounted; strike is surface mounted. Drilled and countersunk for 5.0mm (No. 10) screws

Cylinder locks may be keyed alike or differently; 5 key changes available; please specify.
Models available with heat-resistant, vinyl sleeve

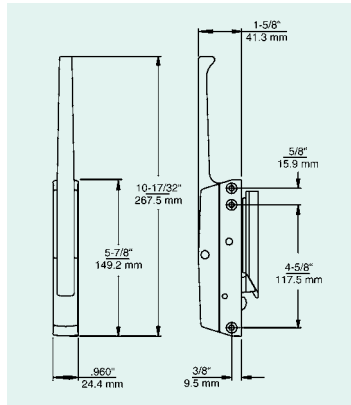
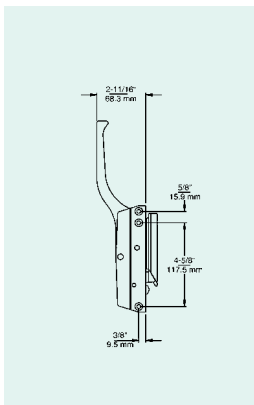

0172000006	Magnetic-Mechanical Latch, Handle: Straight
0172B00006	Magnetic-Mechanical Latch, Handle: Offset
0172C00006	Magnetic-Mechanical Latch, Handle: Straight, Lock: Cylinder
0172BC0006	Magnetic-Mechanical Latch, Handle: Offset, Lock: Cylinder
0172CM0004	Cylinder Kit for 172

Edgemount Mechanical Latches



- Smooth-operating trigger-action latches
- Kason patented two-way adjustable MICROturn strike
- Adjust to compensate for gasket compression and door sag
- Positive, air-tight closure with little force
- Release easily with a finger's pull

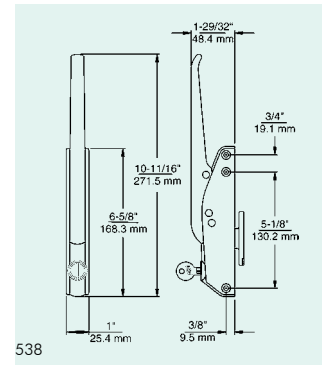
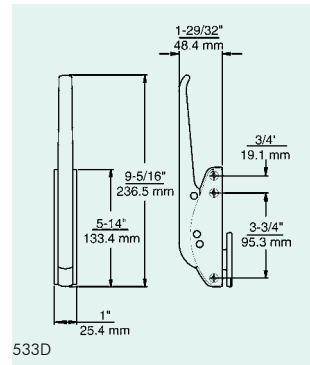

- **Material:** High pressure die-cast zinc body, handle and strike; brass tongue
- **Finish:** Polished chrome
- **Mounting:** Drilled and countersunk for 5.0mm (No. 10) screws

Cylinder locks may be keyed alike or differently; 5 key changes available; please specify.
Models available with heat-resistant, vinyl sleeve

0533D00004	Edgemount Mechanical Latch, Lock: Padlock
0538000004	Edgemount Mechanical Latch, Lock: Padlock
0538C00004	Edgemount Mechanical Latch, Lock: Cylinder
0533D00024	Strike for 533D, 538 and 538C
0538CM0004	Cylinder Kit for 538

535 :: Roller Grip



- Kason Original - the standard for concealed latching. Tapered strike assures complete closure
- Strike adjusts up or down, or side to side
- Use on doors and drawers

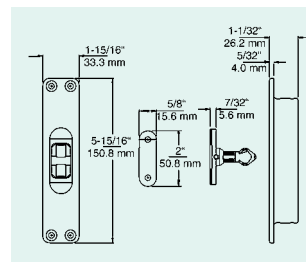

- **Material:** High pressure die-cast zinc tongue housing and strike; nylon rollers
- **Finish:** Polished chrome
- **Mounting:** Tongue housing drilled and countersunk for 5.0mm (No. 10) screws. Strike has slotted screw holes

0535H00004	Roller Grip Latch, Spring: Heavy, Separating Force: 116 to 160N (26 to 36lb)
0535M00004	Roller Grip Latch, Spring: Medium, Separating Force: 85 to 114N (19 to 25lb)
0535L00004	Roller Grip Latch, Spring: Light, Separating Force: 53 to 80N (12 to 18lb)

Edgemount Mechanical Latches

173 / 174 :: Latch Body



- Positive latching keeps door shut tight; guards against pop-opens
- Finger-tip touch opening
- Cylinder locking and non-locking models
- Two-way adjustment compensates for door sag and gasket wear
- Use with all standard gaskets for economical installation
- Compact size fits most units
- **Material:** High pressure die-cast zinc body and handle, die-cast and steel strike
- **Finish:** Polished chrome
- **Mounting:** Latch is edge mounted; strikes are surface mounted. Drilled and countersunk for 5.0mm (No. 10) screws

173 :: Universal Strike

- Latch with universal strike replaces competitive latch
- **Strike Adjustment Range:** 7.1mm to 15.1mm (9/32" to 19/32")
- **Mounting:** Strike drilled for 5.0mm (No. 10) screws

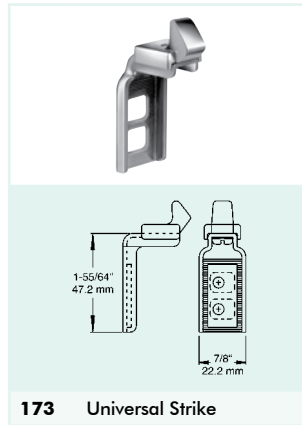

173 Universal Strike

174 :: Standard Strike

- Latch body with 174 standard strike
- **Strike Adjustment Range:** 10.3mm to 18.3mm (13/32" to 23/32")
- **Mounting:** Strike drilled for 5.0mm (No. 10) screws

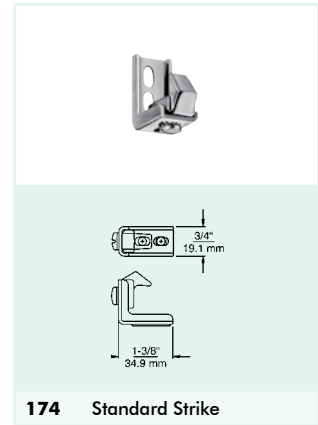

174 Standard Strike

KASON REACH-IN HARDWARE

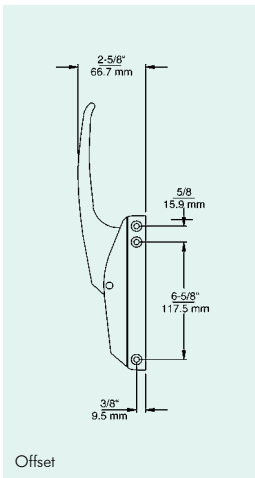

Offset

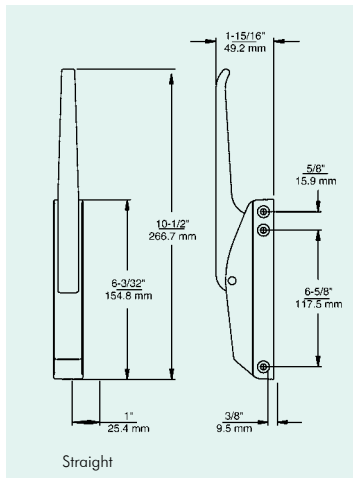

Straight

174B-14 :: Hi-Temp Oven Latch

- Oven Latch with all the benefits of the popular Kason 174 Edgemount Latch
- Heat-resistant brass roller
- Cool-touch handle with plastic sleeve
- Complements Kason No. 1216-31 Hi-Temp brass oven hinge

Cylinder locks may be keyed alike or differently; 5 key changes available; please specify. Models available with heat-resistant, vinyl sleeve



- **Strike Adjustment Range:** 10.3mm to 18.3mm (13/32" to 23/32")

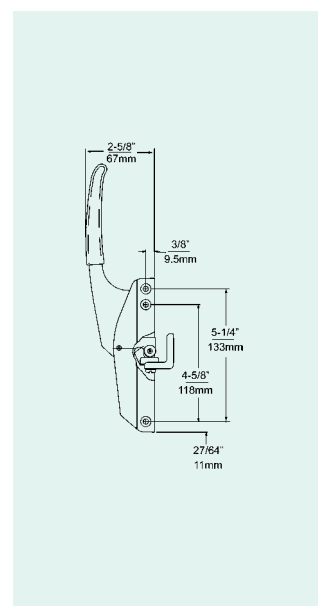

0173000004	Straight Handle, Non-Locking
0173B00004	Offset Handle, Non-Locking
0173C00004	Straight Handle, Cylinder Lock
0173BC0004	Offset Handle, Cylinder Lock
0174000004	Straight Handle, Non-Locking
0174B00004	Offset Handle, Non-Locking
0174C00004	Straight Handle, Cylinder Lock
0174BC0004	Offset Handle, Cylinder Lock
0174B00014	Hi-Temp Oven Latch with Brass Roller and Plastic Sleeve, Offset Handle
0174C00012	Cylinder Kit for 173, 174 and 174B

930 Series :: Trigger Action Latches



- Dependable, time-tested trigger action latch
- Select one of six strikes to customize your application
- Adjustable strikes feature either Kason's patented micrometer or microturn strike for hairline-fine adjustments
- Interchangeable for right or left opening doors
- Standard padlocking feature.
- 930 latch body and strikes may be ordered separately

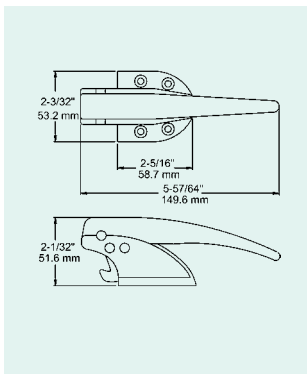

- **Material:** High pressure die-cast zinc body; solid brass tongue
- **Finish:** Polished chrome
- **Offsets:** See ordering information.
- **Mounting:** Drilled and countersunk for 4.0mm (No. 8) screws

Cylinder locks may be keyed alike or differently; 5 key changes available; please specify.
Models available with heat-resistant, vinyl sleeve

0930A0004	Latch with Adjustable Strike A , Offset: 0.0mm to 9.5mm (Flush to 3/8")
0930B0004	Latch with Stationary Strike B , Offset: 6.4mm (1/4")
0930C0004	Latch with 3 hole Micrometer Strike C , Offset: 19.9mm to 31.8mm (3/4" to 1 1/4")
0930D0004	Latch with 3 hole Microturn Strike D , Offset: 22.8mm to 31.8mm (7/8" to 1 1/4")
0930E0004	Latch with 2 hole Microturn Strike E , Offset: 22.8mm to 31.8mm (7/8" to 1 1/4")
0930F0004	Latch with 2 hole Micrometer Strike F , Offset: 19.9mm to 31.8mm (3/4" to 1 1/4")

Strikes

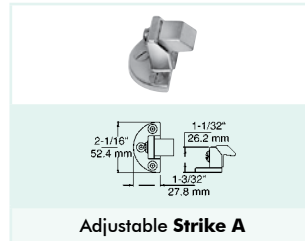

Adjustable Strike A

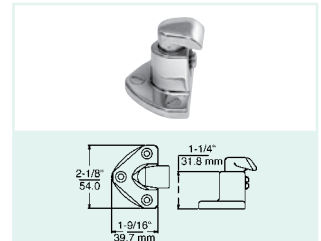

3 hole Micrometer Strike D



Stationary Strike B

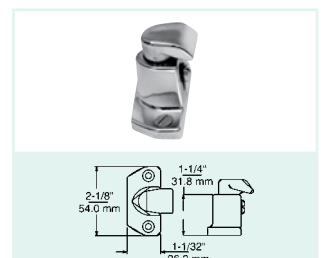

2 hole Micrometer Strike E

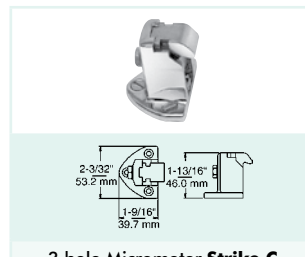

3 hole Micrometer Strike C

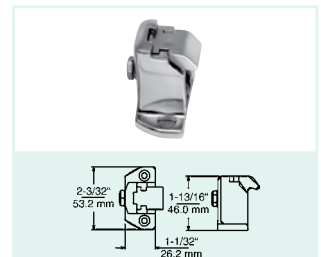

2 hole Micrometer Strike F

KASON REACH-IN HARDWARE

931 :: Trigger Action Latch



- Enlarged version of the popular Kason No. 930, for large reach-in doors
- Includes patented micrometer strike for hairline-fine adjustments

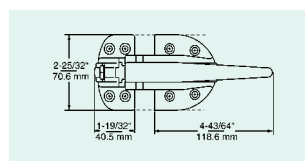

- **Material:** High pressure die-cast zinc body; brass tongue and strike insert
- **Finish:** Polished chrome
- **Mounting:** Drilled and countersunk for 5.0mm (No. 10) screws

0931000004	Trigger Action Latch, Offset: 0-3.2mm (0-1/8")
0931000008	Trigger Action Latch, Offset: 22.2-28.6mm (7/8"-1 1/8")
0931000012	Trigger Action Latch, Offset: 28.6-34.9mm (1 1/8"-1 3/8")

Explosion Venting Latches

- Installs on right or left opening door
- Factory Mutual test rated to release at force of 407N (91.5 lb)

- **Material:** High pressure die-cast zinc body, handle and strike housing; extruded brass tongue and strike insert
- **Finish:** Polished chrome

WARNING: Explosion venting latches are intended to release at designated pressures to protect the enclosures on which they are mounted. Users must determine safe pressure levels for their specific applications. Because installations and environmental conditions vary, regular maintenance and latch function checks are necessary to assure proper operation.

930X Trigger Action



931CX Trigger Action

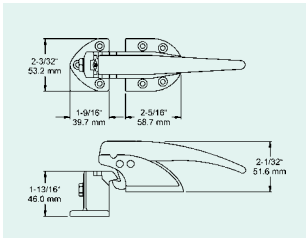

- **Mounting:** Drilled and countersunk for 4.0mm (No. 8) screws

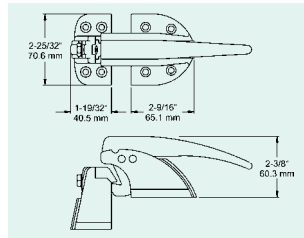

- **Mounting:** Drilled and countersunk for 4.0mm (No. 8) screws

0930AX0004 Explosion Venting Latch, Offset: 0-9.5mm (0-3/8")

0930CX0004 Explosion Venting Latch, Offset: 19.1-31.8mm (3/4"-1 1/4")

0931AX0004 Explosion Venting Latch, Offset: 0-6.4mm (0-1/4")

0931CX0004 Explosion Venting Latch, Offset: 22.2-28.6mm (7/8"-1 1/8")

0931HX0004 Explosion Venting Latch, Offset: 28.6-34.9mm (1 1/8"-1 3/8")

812 :: Cam Action Latch

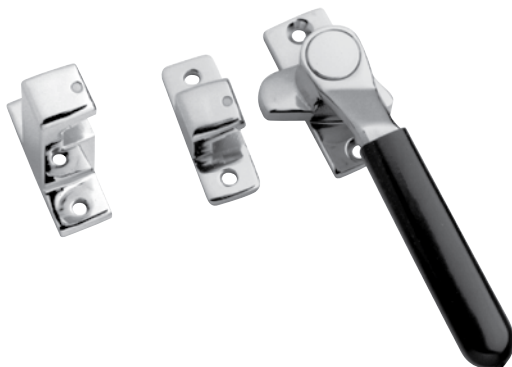

- Engineered specifically for heated cabinets where high gasket compression is required
- Positive cam action maintains tight seal and allows easy opening under varying temperatures
- Easy-grip handle stays cool with hi-temp vinyl insulating sleeve
- Multiple offsets available

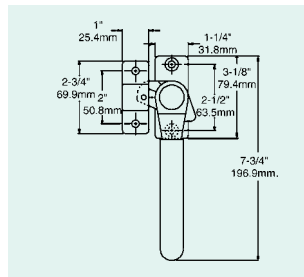

- **Material:** Cast ZA12 alloy handle, strike and base; stainless steel pin
- **Finish:** Polished chrome
- **Offsets:** Flush, 31.5mm (1 15/64"), 46.7mm (1 27/32")
- **Mounting:** Handle drilled and countersunk and strike drilled for 6.0mm (1/4") screws

0812000004 Cam Action Latch, Flush Mount

0812000003 Cam Action Latch, Offset 31.5mm (1 1/4")

0812000002 Cam Action Latch, Offset 46.8mm (1 27/32")

Compensation Valves :: VA Series



- Internal/external pressure compensation valves for low temperature upright freezers and glass cabinets
- Allows doors to be opened and closed frequently without generating the suction effect
- Suitable for assembly in upright or chest freezers with capabilities up to 700-800 litres
- Aluminium valves do not require heating elements since they must be installed close to a source of heat
- Valves equipped with an alimentary thermoplastic cap with a sealing ring gasket



Installation Notes: Drill a through hole, 20mm dia. horizontal for VA 90 and vertical for VA 180

VA 90	Compensation Valve, suitable for installation on the rear wall next to the condenser
VA 180	Compensation Valve, suitable for installation in the motor compartment

0660 Series Energy Saving Condensate Evaporator Trays



- Designed for longer life and energy savings
- Thermostatically controlled, solid state heater provides reliable operation
- Features one-piece pan of corrosion resistant #360 cast aluminium that provides long term performance and requires less frequent cleaning
- Cuts heat loss by directing more heat to the wetted pan areas and less to the pan exterior
- Thermostatically controlled heater lowers wattage automatically to conserve energy when the pan is empty
- Strategic placement of the heating element extends heater life

High Efficiency Energy Saving Evaporator

High efficiency, 225W model achieves up to 90% of the evaporation of a typical high wattage unit, using 25% less energy

- **Material:** Die cast #360 series aluminium pan; spring wire legs
- **Finish:** Natural
- **Power Supply and Connection:** See product table below
- **Volume:** 1479ml (50fl.oz)
- **Size:** 120 x 317 x 73mm (4 3/4" x 12 1/2" x 2 7/8")

Optional Wall Mounted Bracket

- Bracket mounts to back of cabinet
- Pan snaps in place

Product Code	Evaporation Rate
066000006	118ml (4.0oz)/hour
066000036	157ml (5.3oz)/hour

0660000006	220V, 160W, with 457mm (18") wire leads
0660000036	220V, 225W, with 1829mm (72") wire leads
0660000064	Wall Mounted Bracket

