

Gas Interlock System & Canopy Fittings

	G.I.S. :: Gas Interlock System 8-10
	Cuts off gas flow in the event of kitchen extract fan failure
	G.P.S. :: Gas Proving System 11
	Gas supply cannot be switched on if insufficient pressure
	Baffle Filters 12
	Large range of aluminium and stainless steel sizes
	Surface Mounted Bulkhead Lamp Fixture 13
	Fixture housing & globe
	Canopy Lamps :: Twin 13
	Twin recessed & twin surface mounted
	Silicone Sealant 14
	Range of sealants & gun
	Divider Bar & Cap Strip 14
	Stainless steel

G.I.S. :: Gas Interlock System

CUTS OFF GAS FLOW IN THE EVENT OF KITCHEN EXTRACT FAN FAILURE NOW A MANDATORY REQUIREMENT IN MOST COMMERCIAL KITCHENS

HOW G.I.S. WORKS

Sensors placed either side of the ductwork fan monitor air pressure. They are connected to an air differential switch, which is activated when the pressure difference changes. Alternatively the current taken by the fan can be monitored by a fan power sensor. The 230V G.I.S. monitors this switch/sensor and in the event of fan failure will close the gas solenoid and cut off the gas flow to kitchen appliances.

WHEN IS A GAS INTERLOCK SYSTEM A MANDATORY REQUIREMENT?

- On installation of a completely new extraction/ventilation canopy
- On installation of a completely new gas pipework run
- On installation of a completely new cook line or layout
- With any fitting of Category 'B' equipment e.g. combination ovens, deep fryers, grills, charcoal griddles. This includes replacements to an existing layout

G.I.S. & CANOPY FITTINGS

SYSTEM REQUIREMENTS

- GIS - One of G01N, G02, G02R, G04, G05
- Air Differential Pressure Switch OR Fan Power Sensor
- Electrically operated normally closed, Gas Safety Shut-off Solenoid Valve
- Remote Emergency Shut-Off Switch (Optional)

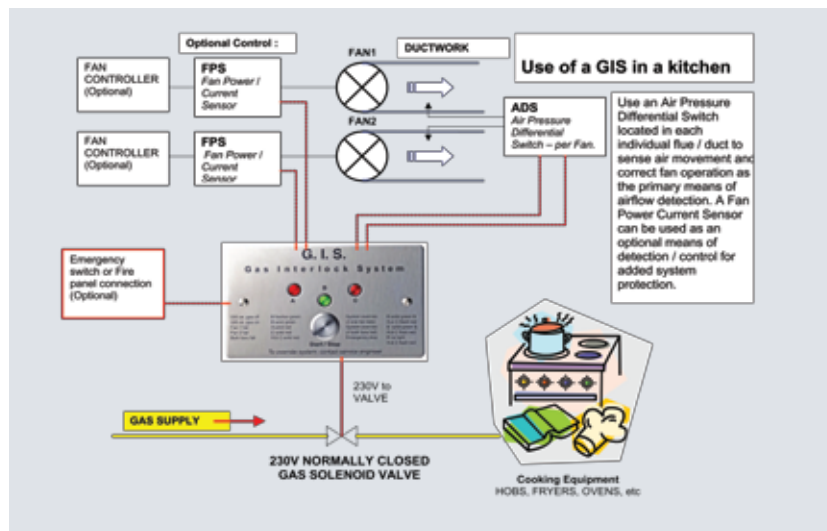

OPTIONAL EXTRAS

- Honeywell Gas Solenoid Valves for pipe sizes 1/2" to 4"
- Air Differential Pressure Switch with 2 metres of tubing
- Fan Power Sensor
- Remote Emergency Cut-Off Switch
- Gas Proving System

Important documents / notes for your consideration and reference:

- Corgi Technical Bulletin - TB 130 BS 6173
- Gas Supply (Installation and Use) Regulation GSIUR27-4
- HSE Information sheet No 23 – Gas Safety in Catering and Hospitality
- HSE CIS Sheet No. 10 - (Rev. 1)
- HVCA Guidance - DW 172

Gas Interlock System & Canopy Fittings

G.I.S. :: Controller :: G01N

ADVANTAGES OF THE G01

Brushed stainless steel fascia fits 44mm deep surface gang box (white plastic box supplied). GIS standard box can be recessed into wall for flush fitting. (Hole size required – 150mm wide, 90mm high, 45mm deep. Minimum hole size required for GIS to fit through a Panel – 130mm width, 80mm height.)

Benefits

- Clear and simple instructions with diagrams
- **Easy to Operate** One button operation. All features explained fully on the fascia plate
- **Highly Competitive Price** One of the most competitive gas interlock system on the market with numerous functions as standard
- **Instant Delivery** Next day delivery anywhere in the U.K. from stock

Features

- Complies with BS6173(2001) and Regulation 27(4) of the Gas Safety (Installation and Use) Regulations 1998
- Each G.I.S. can handle one or two fans
- Multiple G.I.S.'s can be wired together to operate more than two fans
- Back pressure sensitive – 10 second activation delay
- LED lamps and high quality components
- Easy to clean and protected to IP56
- Surface or recessed installation – neat and compact
- Manufactured in the U.K. with a one year parts guarantee



FP1

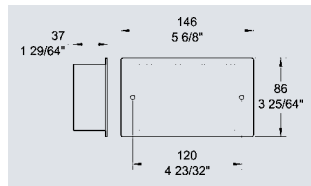

G01 N	G.I.S. with no manual override
FP1	Finger plate for recessed G01 in brushed stainless steel

G.I.S. :: Controllers :: G02, G02R

ADVANTAGES OF THE G02

Smartest and most compact design on the market

Oxford Hardware then introduced an improved and evolved Gas Interlock System since overrides were phased out.

The 'R' model has an emergency cut off switch built in.

Benefits:

- Market leading GIS System
- Market leading Fan Power Sensors and Air Differential Pressure Switches available
- All models can monitor 2 fans
- Larger back box allows easy access for wiring
- Option of built-in Emergency Stop
- Anti Back Pressure feature on all models
- Competitively priced
- All GIS items are available Ex-Stock
- Manufactured in the U.K. with a one year parts guarantee



G02R :: Includes built in emergency cut off

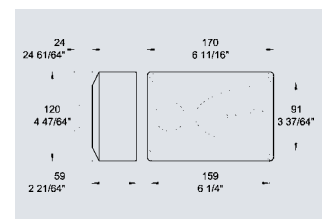

G02	G.I.S. Single Sensor
G02R	G.I.S. Single Sensor, Built-in Emergency Cut-Off

G.I.S. :: Controllers :: G04, G05 :: With Built-in Sensors and Fan Speed Controllers

Oxford Hardware can now introduce two new members to the evolving GIS family: the G04 and the G05

Key Points:

- G05 is a single box with two Fans On/Off, two Fan Speed Controllers, two Fan Power Sensors and the Gas Interlock Panel
- G04 is the economy model with connections for Air Differential Pressure Switches, two Fans On/Off, two Fan Speed Controllers and the Gas Interlock Panel
- More competitive solution than buying separate components
- Large saving on cost of wiring individual components
- Each model can monitor two fans
- Modern design and most compact product on the market (smaller than A4)
- All items in stock for next day delivery

Features:

- Easy to install
- Easy to operate. Complete and simple instructions on the fascia
- All pre-wired internally
- Audible alarm
- Built-in Emergency Stop
- Connections for Remote Emergency Stop and Fire Alarm Panel
- Anti back pressure feature (ignores back draughts in ducting)
- Large heatsink increases life of unit
- Fan soft start feature
- Made in U.K. and C.E. marked
- Guaranteed for parts only against manufacturing defects for one year



G04

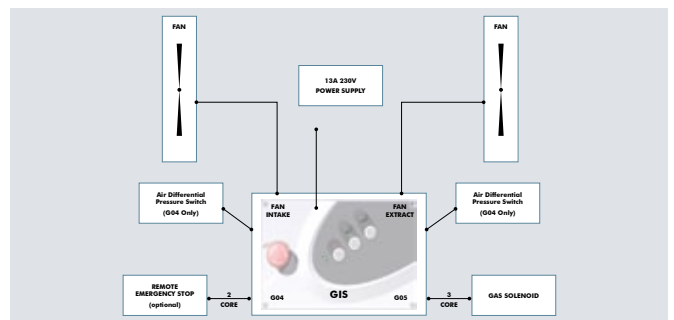
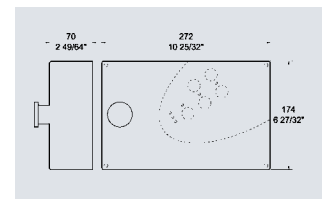

G04	GIS including fan speed control
G05	GIS including fan speed control and current sensors

G.I.S. :: Accessories



SYSTEM REQUIREMENTS

- GIS - One of G01N, G02, G02R, G04, G05
- Air Differential Pressure Switch OR Fan Power Sensor
- Electrically operated normally closed, Gas Safety Cut-off Solenoid Valve
- Remote Emergency Shut-Off Switch (Optional)

G.I.S. & CANOPY FITTINGS

G.I.S. :: Fan Power Sensor

ADVANTAGES OF THE FAN POWER SENSOR (FPS 55 or FPS 330)

- Monitors over and under power consumption
- Can detect blocked filters and loss of impellers
- Alternative to Air Differential Pressure Switch (ADS20)
- Two models cover all relevant fan sizes from 50W (0.2A) to 3kW (13A)
- Fan power sensor is tuned by installer to the exact output of each fan
- Designed to allow for electrical current variation caused by fan controllers
- G.I.S. can monitor two Fan Power Sensors
- Suitable for single and three phase supply



G.I.S. :: Air Differential Pressure Switch

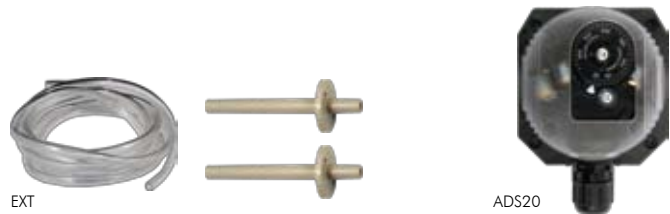

ADS20	20-300Pa air differential pressure switch and 2meters of piping
EXT	Extension kit including 2 metres additional piping and 2 connectors
ADSBRACKET	Bracket for ceiling mount

G.I.S. :: Emergency Switch



RECS Remote emergency cut-off switch

G.I.S. :: Gas Solenoid Valves

- Normally closed gas solenoid valve
- CE Approved and compliant with EN161
- 230V
- Manufactured by Honeywell



VE050	12mm (1/2")
VE075	19mm (3/4")
VE100	25mm (1")
VE125	32mm (1 1/4")
VE150	38mm (1 1/2")
VE200	50mm (2")
VE250	62mm (2 1/2")
VE300	75mm (3")
VE400	100mm (4")

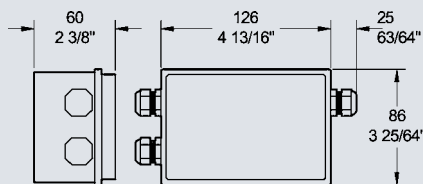

FPS 55	Fan power sensor for fans 50W (0.2A) to 500W (2.2A)
FPS 330	Fan power sensor for fans 300W (1.3A) to 3kW (13A)

G.P.S. :: Gas Proving System



VEGP As Shown: Left Hand Version

- Ensures that the gas supply cannot be switched on if appliances or pipes are leaking
- Equipment includes modified solenoid and G.P.S. control box
- Order as Left OR Right Handed
- Easy to fit as all pre-wired
- Requires G.I.S. box (see previous page) to operate
- Simple and failsafe test takes less than 20 seconds
- High quality components (Honeywell & Dungs)
- To suit gas supplies from 3/4" to 2"

Why fit Gas Proving?

To comply with current gas regulations, any kitchen fitted with gas appliances that do not have flame safety devices is advised to have a gas proving system installed to comply with CORGI best practice. G.P.S. is designed to match and work with any one of Oxford Hardware's Gas Interlock Systems (G.I.S.).

Operation

Check all pilot lights are extinguished. Turn on fans. Activate gas interlock system by pressing START button on G.I.S. Conduct gas proving by pressing START button on gas proving system (G.P.S.). Hold the button for up to 20 seconds. If pressure in the system is sufficient then the solenoid will open and allow the gas to flow to the appliances.

Designed to work with G.I.S. which should be ordered separately

VEGP075 LH/RH	19mm (3/4") normally closed gas solenoid valve with Gas Proving System
VEGP100 LH/RH	25mm (1") normally closed gas solenoid valve with Gas Proving System
VEGP125 LH/RH	32mm (1 1/4") normally closed gas solenoid valve with Gas Proving System
VEGP150 LH/RH	38mm (1 1/2") normally closed gas solenoid valve with Gas Proving System
VEGP200 LH/RH	50mm (2") normally closed gas solenoid valve with Gas Proving System

Baffle Filters



Why use Baffle Filters?

There is an increasing need to maintain and improve hygiene standards and reduce fire hazards within kitchens. The baffle grease filter accomplishes both needs through its clever design of interlocking baffles that provide a tortuous route for the passage of air through the filter by creating two rapid 180° air direction changes simultaneously. The grease molecules having a far greater inertial force than air, impact themselves on the vanes.

A series of vertical Stainless Steel vanes are housed in a channel frame, with each of the baffles strategically aligned to provide the highest potential for grease removal. Due to the smooth nature of the vanes the grease naturally runs downwards, through the drainage holes and into the collecting trays normally provided within the canopy holding casings.

The filters comply with the requirements of DW.172 and LPS.1263 (13.1). Approved to DIN18869-5.

Ordering Example

The Product Code box below shows the dimensions of each baffle filter available. The Dimensions are written as (Height x Width x Depth). See illustration Right

- Heat, flame and grease proof
- All filters complete with handles
- Easily cleaned in a dishwasher or by soaking or spraying

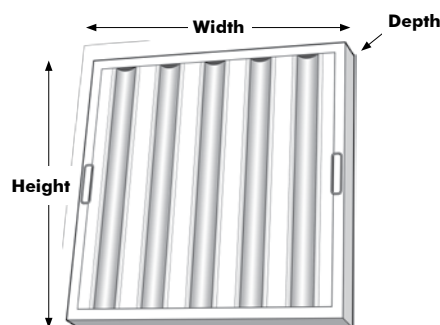

Baffle Filters :: Stainless Steel

Volume	SSSF1020			SSSF1616			SSSF1818		
	240 x 490 x 48mm		390 x 390 x 48mm		440 x 440 x 48mm		440 x 440 x 48mm		
cfm	m ³ /hour	Δ P (Pa)	Δ P (Pa)	Δ P (Pa)	Δ P (Pa)	Δ P (Pa)	Δ P (Pa)	Δ P (Pa)	
74	125	35	30	18					
148	250	62	50	30					
221	375	94	72	44					
295	500	120	95	58					
369	625	150	118	74					
443	750	180	141	87					
516	875		165	101					
590	1000		188	116					
664	1125			130					
738	1250			145					
811	1375			154					
885	1500			164					
959	1625			183					
1033	1750			203					

Technical Data

* Note Baffle filters may be used at higher rated capacities whilst retaining their efficiency, however it should be noted that this will increase their resistance to air

Recommended airflow at 1.8 metres per second

Gravimetric efficiency 65% to 75%

Initial pressure difference: 80 Pa

Final pressure difference: No difference

Fire resistant: MO

Packaging: Boxes of 6

- SSSF1020** Baffle filter 245 x 490 x 48mm, (10 x 20 x 2")
- SSSF1616** Baffle filter 390 x 390 x 48mm, (16 x 16 x 2")
- SSSF2016** Baffle filter 490 x 390 x 48mm, (20 x 16 x 2")
- SSSF1818** Baffle filter 440 x 440 x 48mm, (18 x 18 x 2")
- SSSF2424** Baffle filter 590 x 590 x 48mm, (24 x 24 x 2")

Baffle Filters :: Stainless Steel :: Mirror Finish

- This pair of filters are slightly differently designed and come mirror finished

Optimal Conditions:

Front air velocity between 1.10 and 1.33m/s.
Flow rate for standard filter (500 x 500 x 50mm) is between 1.000 and 1.200m³/h

Optimal Working Conditions		
Air Flow Rate	Face Velocity	Initial Pressure Drop
1.100m ³ /h	1.25m/s	4mm c.d.a
1.200m ³ /h	1.40m/s	4mm c.d.a
1.500m ³ /h	1.70m/s	8mm c.d.a
1.800m ³ /h	2.00m/s	16mm c.d.a

NB: The pressure drop is constant

- BSSF1620** Baffle filter 400 x 495 x 48mm, (16 x 20 x 2")
- BSSF2020** Baffle filter 500 x 495 x 48mm, (20 x 20 x 2")

Baffle Filters :: Aluminium

Flow Rate (cfm)	AIR FLOW CHARACTERISTICS						Static Pressure	
	10 x 20	12 x 16	12 x 20	16 x 16	16 x 20	20 x 20	16 x 25	20 x 25
200	0.13	0.15	0.10	0.07	0.04	0.04	0.04	0.03
250	0.20	0.23	0.16	0.12	0.07	0.06	0.07	0.04
300	0.29	0.33	0.23	0.17	0.09	0.08	0.09	0.06
400	0.52	0.59	0.40	0.30	0.17	0.15	0.17	0.11
450	0.66	0.75	0.51	0.38	0.21	0.19	0.21	0.14
500	0.81	0.93	0.63	0.46	0.26	0.23	0.26	0.18
550	0.98	1.12	0.76	0.56	0.32	0.28	0.32	0.21
600	1.17		0.90	0.67	0.38	0.33	0.38	0.25
650			1.06	0.79	0.45	0.39	0.44	0.30
700				0.91	0.52	0.45	0.51	0.35
750				1.05	0.59	0.52	0.59	0.40
800					0.68	0.59	0.67	0.45
850					0.76	0.67	0.75	0.51
900					0.85	0.75	0.85	0.57
950					0.95	0.83	0.94	0.64
1000					1.05	0.92	1.04	0.71

Depth: 46mm (1 13/16")
Stocked sizes are in **BOLD**

- ALF1016** Aluminium Baffle Filter, 250 x 410mm (10 x 16")
- ALF1216** Aluminium Baffle Filter, 300 x 410mm (12 x 16")
- ALF1616** **Aluminium Baffle Filter, 410 x 410mm (16 x 16")**
- ALF2016** **Aluminium Baffle Filter, 500 x 410mm (20 x 16")**
- ALF2516** Aluminium Baffle Filter, 640 x 410mm (25 x 16")
- ALF1020** Aluminium Baffle Filter, 250 x 500mm (10 x 20")
- ALF1220** Aluminium Baffle Filter, 300 x 500mm (12 x 20")
- ALF1620** **Aluminium Baffle Filter, 410 x 500mm (16 x 20")**
- ALF2020** **Aluminium Baffle Filter, 500 x 500mm (20 x 20")**
- ALF2520** Aluminium Baffle Filter, 640 x 500mm (25 x 20")
- ALF1025** Aluminium Baffle Filter, 250 x 640mm (10 x 25")
- ALF1225** Aluminium Baffle Filter, 300 x 640mm (12 x 25")
- ALF1625** Aluminium Baffle Filter, 410 x 640mm (16 x 25")
- ALF2025** Aluminium Baffle Filter, 500 x 640mm (20 x 25")

Canopy Lamps :: Twin



- High quality but economically priced
- Easy lamp replacement
- One side hinged, other side quick release
- Option of recessed or surface mounted fitting
- High frequency balance and triphosphor tubes included
- LUX Rating 439 (2ft), 1117 (4ft)
- Heat, flame and grease proof
- DW172 compliant
- Rated IP55

CLSM2 Twin 18W Surface mounted 2ft

CLSM4 Twin 36W Surface mounted 4ft

CLR2 Twin 18W Recessed 2ft

CLR4 Twin 36W Recessed 4ft

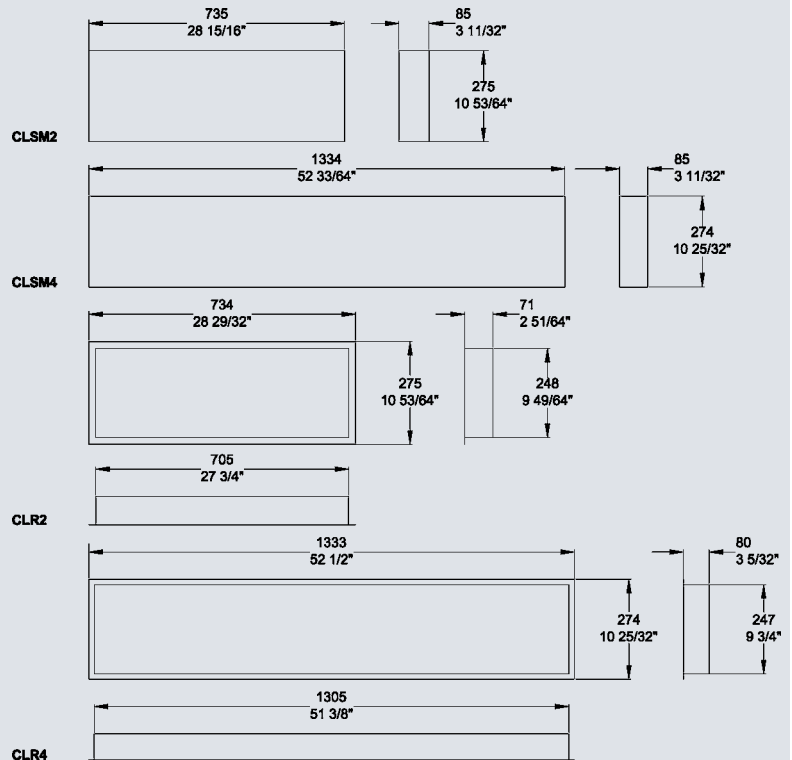

Product Code	Main body Dimensions H x W x D	Width of end and side flange	Cut out required
CLSM2	275 x 735 x 85 (10 53/64" x 28 15/16" x 3 11/32")	X	X
CLSM4	274 x 1334 x 85 (10 25/32" x 52 33/64" x 3 11/32")	X	X
CLR2	248 x 705 x 71 (9 49/64" x 27 3/4" x 2 51/64")	15 (19/32")	709 x 252 (27 29/32" x 9 15/16")
CLR4	247 x 1305 x 80 (9 3/4" x 51 3/8" x 3 5/32")	15 (19/32")	1309 x 251 (51 17/32" x 9 7/8")

Surface Mounted Bulkhead Lamp Fixture



- Sanitary, rustproof, cast aluminum fixture
- Impact and thermal shock-resistant, tempered glass globe
- Approved UL, NSF, SA
- **Material:** Die-cast aluminium alloy, brushed finish
- **Globe:** Tempered glass
- **Socket:** Porcelain body, nickel plated copper shell
- **Lamp:** Accepts 100W max Eddison screw bulb (not included)
- **Gaskets:** Silicone
- **Wire leads:** 15.2cm (6") long
- **Size:** Housing and globe, 14cm (5-1/2") dia. x 21.6cm (8-1/2") high
- **Mounting:** To standard 8.9cm (3-1/2") or 10.2cm (4") junction box

OHBL01 Fixture housing

OHBL02 Globe

Silicone Sealant

G.I.S. & CANOPY FITTINGS



- High modulus acetox cure silicone
- Sturdy 10" gun suits 310 & 380ml cartridges
- All products manufactured to BS
- Orders can be placed for less than boxed quantities

Product Code	Packaging Ref.	Colour / Type	Temperature Limit °C	Cartridge Size (ml)	Quantity in Box
S90-1010	1	Clear	120	310	20
S90-1011FS	2	Clear - Food Safe	200	310	20
S90-1012FS	2	Aluminium - Food Safe	200	310	20
S90-1014	1	White	120	310	20
S90-1015FS	2	White - Food Safe	200	310	20
S90-1016	1	Black	100	310	20
S90-1021FS	2	Black - Food Safe	250	310	20
S90-2020	3	Standard Duct Seal	25	310	25
SGUN	6	Cartridge Gun	-	310/380	1

S90-1010	Clear
S90-1011FS	Clear - Food Safe
S90-1012FS	Aluminium - Food Safe
S90-1014	White
S90-1015FS	White - Food Safe
S90-1016	Black
S90-1021FS	Black - Food Safe
S90-2020	Standard Duct Seal
SGUN	Cartridge Gun

Divider Bar

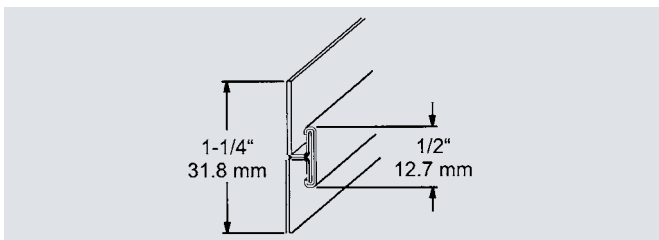

43 764 1449 8ft Divider bar 1/16" stainless steel, 2mm gap

Cap Strip

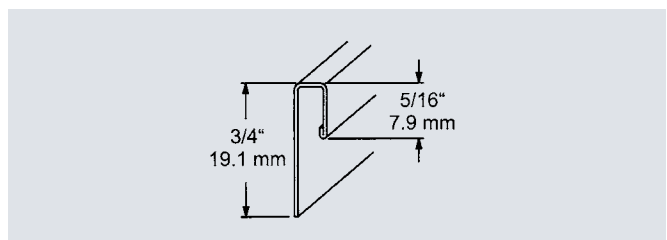

45 763 1458 8ft Cap strip 1/16", stainless steel, 2mm gap